

Ferrite Magnet Die-cast Chassis Driver



Features

- 5" Very Large Format Voice Coil
- 6000 Watts Peak Power Handling
- Active Balanced Cooling
- Ferrite Magnetics
- Copper wire Inside/Outside Coil Design
- Double Spiders Suspension
- Integrated Demodulation Rings
- Die Cast Aluminum Chassis

Applications

The P Audio GST-181500 is an 18 inch (457mm) diameter high performance very low frequency sub woofer transducer. The design utilizes a very large format 5 inch (127mm) nominal voice coil diameter with a very high power copper based coil configured in an inside/outside wind geometry. The large radiating area and deep bass performance insure that the GST-181500 is capable of very high impact low frequency response. The transducer also offers a double silicone spider design that improves long term mechanical reliability and mechanical linearity. The large format ferrite based magnet structure produces very high conversion efficiency. The ferrite design includes a double stack permanent magnet geometry that increases maximum physical excursion capability. Inside/outside winding geometry assists in coil cooling and improves both transducer power handling and system reliability. The GST-181500 also features a very long air gap height that improves transducer linearity.

The design features very large diameter silicone impregnated spiders to insure long term linearity. The GST-181500 also incorporates a proven double spider design that effectively controls off axis displacement of the coil assembly. The silicone impregnated spiders and very high system power handling will insure excellent long term performance. The cone is waterproof to improve reliability in high humidity environments.

The GST-181500 offers very smooth and controlled amplitude response and has a recommended high frequency limit of 150Hz. The rated low frequency limit of 35Hz will insure excellent low frequency extension and very deep bass response. The GST-181500 is an excellent choice for high output sub woofer system designs where extended deep bass energy is specified. The design also features a very high strength to weight ratio cone design. The GST-181500 is ideally suited to vented enclosure designs and can be coupled with a wide range of top box enclosures.

The GST-181500 features an aluminum die cast chassis that includes P Audio's "Auto Balanced Cooling" design that minimizes coil and magnet structure heating, and further improves system performance. The rated continuous power handling is 1500 watts (AES) and offers a peak power handling rating of 6000 watts when sufficient amplifier headroom is available.

Specifications

General Specifications

Nominal diameter.....	457 mm/18 in
Power rating.....	1500 W(AES)
Nominal impedance.....	8Ω
Sensitivity.....	96 dB
Frequency range.....	30-1000 Hz
Chassis type.....	Cast aluminum
Magnet type.....	Ferrite
Magnet weight.....	8.9 kg/312.5 oz
Voice coil diameter.....	127 mm/ 5 in
Coil material.....	Copper wire
Former material.....	Glass fiber
Cone material.....	Paper
Surround material.....	Cloth
Suspension.....	Double
X-max.....	9 mm/0.35 in
Gap depth.....	14 mm/0.55 in
Voice coil winding width.....	32 mm/1.26 in
Net Weight.....	24.8 kg/54.7 lbs
Packing Dimension WxDxH.....	505 x 505 x 300 mm
Shipping Weight.....	26.9 kg/59.3 lbs

Small Signal Parameters

Re.....	5.6 Ω
Fs.....	37 Hz
Mms.....	285.75 g/10.08 oz
Mmd.....	261.09 g/9.21 oz
Qms.....	13.15
Qes.....	0.52
Qts.....	0.50
Vas.....	135.51 lt/4.79 ft ³
SD.....	1225 cm ²
Bl.....	26.87 Tm
Cms.....	6.5e-05 m/N
Rms.....	5.10 Ns/m
Le (at 1kHz).....	0.72 mH

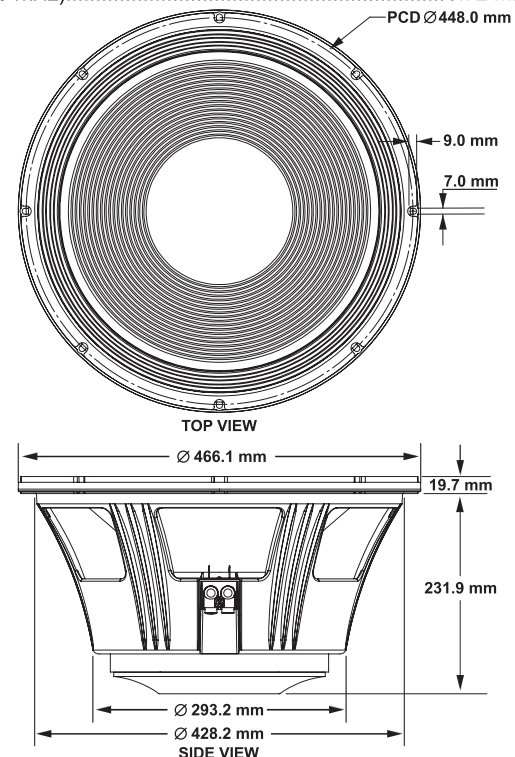

Frequency Response and Impedance Curves

