

High Output Compression Driver

The P Audio BM-D442 is a 1.75 inch (44.4mm) medium format diaphragm compression driver coupled to a high density magnetic circuit. The compression driver exit diameter is an industry standard 1 inch (25.4mm). The design of the 442 is based on the extremely successful BM-D440 technology and represents substantial technological advances in both sound quality and ease of integration into system designs. The BM-D442 combines high magnetic field strength and a very lightweight diaphragm assembly, producing in a very high output device that also features extended bandwidth and well defined frequency response. The phase plug is a circumferential slot design that has been redesigned to provide both extended bandwidth and superior response linearity. The phase plug to diaphragm spacing has been optimized for both extended frequency response and increased acoustic damping. The BM-D442 is optimized for very high performance two way system designs and is an excellent high frequency device for professional two way systems. The driver has a rated low frequency response limit of 1.5kHz and features extended response to beyond 20kHz.

The BM-D442 is a Ferrite based magnetic system with an FEA (Finite Element Analysis) modeled magnetic circuit designed to yield very high magnetic density and high acoustic conversion efficiency. The light weight titanium diaphragm design and optimized geometry insure extended response and extremely high reliability. The magnetic circuit and phase plug geometry are an integrated design that yields an excellent combination of both mechanical and acoustical conversion efficiencies.

The BM-D442 features an industry standard bolt-on style mounting system that is ideally mated to all P Audio PH series high frequency horns as well as any industry standard high frequency horn that can accommodate a standard 1 inch "bolt-on" mounting pattern.



Specifications

Throat Diameter	1.0 inch (25.4mm)
Diaphragm Diameter	1.75 inch (44.4mm)
Nominal Impedance	8 Ohm
Voice Coil DC Resistance	6.8 Ohm
Power Handling	50 Watt
Sound Pressure Level (1W@1M) (Loaded with 90x40 Horn)	108 dB
Mounting Type	Bolt On
Magnet	Ferrite
Diaphragm Material	Titanium
Recommended Crossover	1.5kHz or higher (12dB/Oct slope)
Net Weight	1.9kg (4.2lbs) 1pc
Gross Weight	4kg (8.8lbs) 2pcs
Packing Dimension HxWxD(cm)	29 x 14.1 x 10.3 (0.15 Cu.Ft.)

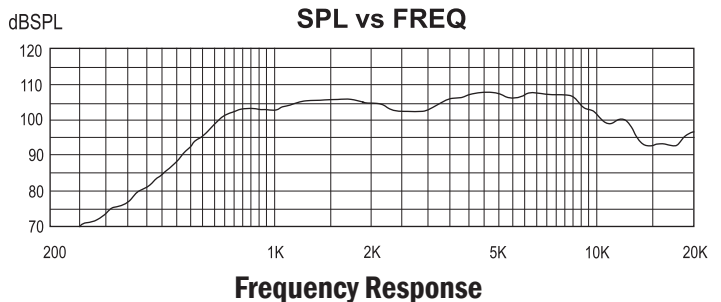
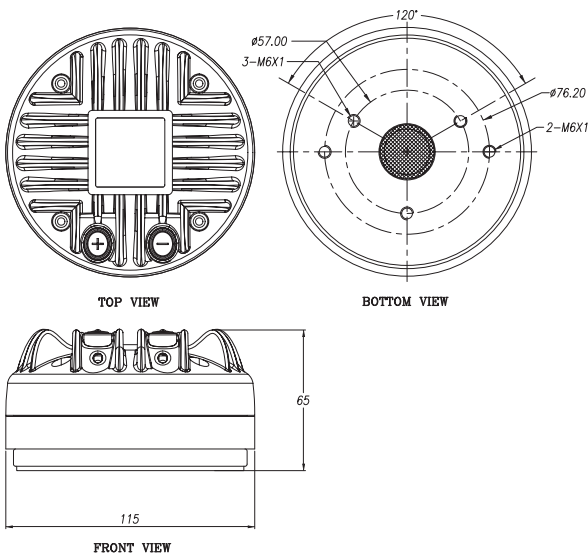

19/4 Moo 2 T.Bangkratok A. Samparn Nakornpathom 73210 Thailand
 Tel: +66-2-441 6600 Auto 30 Lines
 e-mail: info@paudiothailand.com
 Web site: www.paudiothailand.com
 All rights reserved by P.Audio System Co., Ltd. 2007

