



## INSIDE ONLY VOICE COILS

The function of a loudspeaker is to convert electrical energy to an analogous acoustical energy. This conversion process takes place in two steps. The first step is the conversion from electrical energy to mechanical energy. The second step is a conversion from mechanical energy to acoustical energy.

The first step consists of generating a mechanical displacement proportional to the electrical input signal. The second step consists of coupling the mechanical displacement of the system to the surrounding air via some mechanism, such as a diaphragm, usually referred to as a cone.

A class of loudspeakers known as electro-dynamic employs a combination of permanent magnet and electro magnet to produce the conversion of electrical to mechanical energy. The permanent magnetic structure in this type of loudspeaker utilizes a permanent magnetic material, such as neodymium iron boron, aluminum nickel cobalt, or other rare earth or ceramic materials, that is placed in a “magnetic circuit”. This “circuit” consists of a plate of low carbon steel on the north magnetic pole of the permanent magnet and another plate of low carbon steel on the south magnetic pole of the permanent magnet. Either the plate on the north magnetic pole or the plate on the south magnetic pole is shaped to provide a small magnetic gap. This magnetic gap is usually annular in geometry but need not necessarily be of an annular geometry to be functional. The “magnetic gap” then has a high magnetic field strength. The low carbon steel plates act to concentrate the magnetic field in a volume of space known as the magnetic gap.

The electro magnet portion of the transducer consists of a length of electrical conductor. When a time varying electrical current flows through the conductor a magnetic field is produced around the wire and that magnetic field is proportional to the magnitude of the electrical current flowing through the wire. It is a common practice to form the length of electrical conductor into a coil. This coil is usually referred to as the Voice Coil. If the permanent magnetic gap is an annular geometry then the electro magnet coil may be immersed into the permanent magnetic gap. This gives rise to a force of interaction between the permanent magnetic field and the electro-magnetic field. This force is known as the Lorentz force and is shown in algebraic form as  $F=BLi$  where  $F$  is the force of interaction between the two magnetic fields.  $B$  is the magnitude of the permanent

magnetic field and  $L$  is the length of wire immersed in the permanent magnetic field and associated with the coil. “ $i$ ” is the magnitude of the electrical current flowing thru the wire.

The force of interaction between the permanent magnetic field and the electro-magnetic, or coil, will produce an acceleration in accordance with Newton’s laws of motion.

Figure 1 is a typical magnetic circuit known as a “Pot Core” style. The permanent magnetic material (shown in red) has a soft piece of low carbon steel known as a Pole Tip and the top is relative to the magnetic axis of the permanent magnet. The low carbon steel “return path” is located on the opposite side from the pole tip and is also on the magnetic axis of the permanent magnet. The return path is formed to produce a Magnetic Gap, as shown in figure 1. The electro-magnet or voice coil is then immersed in the permanent magnetic gap as shown in figure 1.

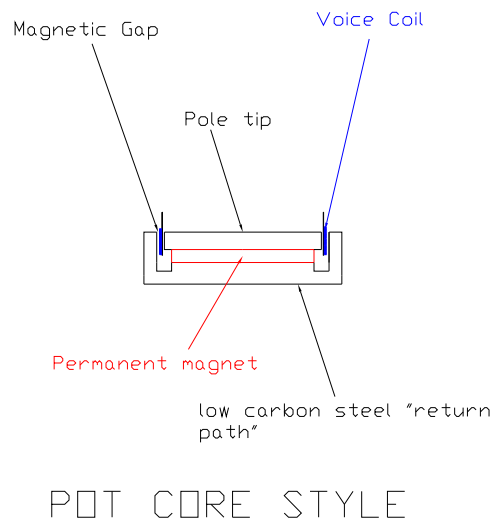
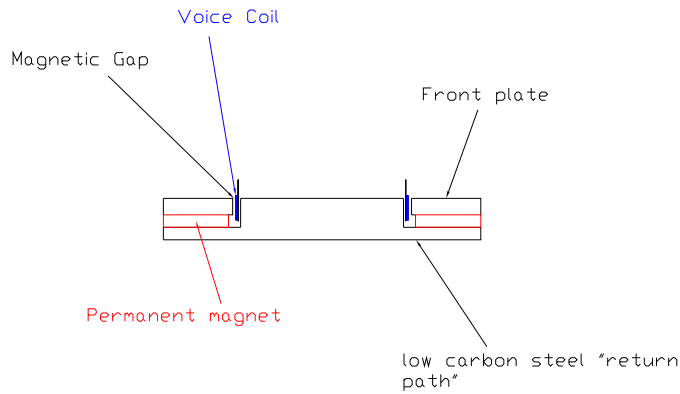

FIGURE 1

The second common permanent magnet structure geometry is shown in figure 2. This style is sometimes referred to as a “pancake” style. This style of permanent magnetic structure performs an identical function to the pot core style in that the low carbon steel return path and front plate still act to form an annular magnetic gap. The voice coil is then immersed in the magnetic gap and the result is a force of interaction between the electro-magnetic voice coil and the permanent magnet field.



"PANCAKE" STYLE

FIGURE 2

In both figures 1 and 2, the force of interaction will produce a physical displacement of the voice coil. This physical displacement will be a function of the polarity of the permanent magnetic field and the polarity of the time varying electrical current flowing thru the voice coil. The direction of the voice coil displacement will be either up or down along an axis as shown in figure 3.

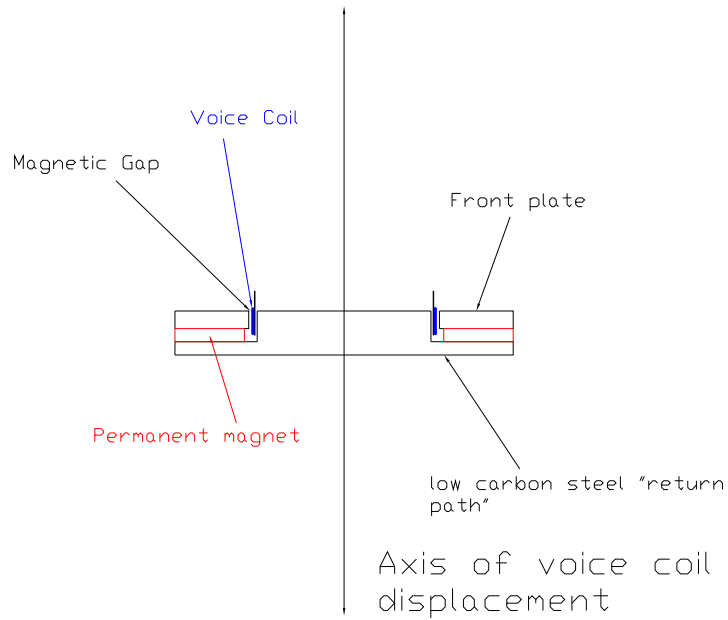

FIGURE 3

The ability of the loudspeaker to convert electrical signals to proportional mechanical displacements and subsequently to acoustical energy is often referred to as the conversion efficiency of the transducer, or loudspeaker. The conversion efficiency is proportional to Lorentz force as well as the total moving mass of the loudspeaker, including voice coil, cone, dust cap, and all parts of the transducer that move relative to the permanent magnet structure and frame.

The efficiency of loudspeakers, like all transducers, can be rated as a percentage of the input power to the output power. Typical loudspeakers can range from less than 1% efficient to over 30%. The conversion efficiencies approaching 30% are for a specific type of loudspeaker referred to as compression driver. Typical (non compression driver) loudspeakers range from 1% to 5% efficiency but can be lower or higher as well. These efficiency levels relate the ratio of the electrical input to the acoustic output. As an example, 100 electrical watts of power are typically converted to 3watts to 4 watts of acoustic power for a 3% to 4% efficient loudspeaker. The remaining electrical power is converted to heat.

Loudspeaker voice coils can be heated to temperatures of over 450 F degrees (232C). These heat levels are extreme and can produce device failure due to degradation of the adhesive systems used to bond the voice coil to its carrier as well as the adhesives used to bond each turn to the next on the voice coil itself. In addition to device failure, the voice coil DC resistance is also affected by heat. Every alloy of conductor has a Temperature Coefficient of Resistance. This coefficient relates the temperature of the conductor to the dc resistance of the conductor. As the temperature increases, the dc resistance of the conductor also increases. As the dc resistance increases the current flow thru the conductor decreases and is described by Ohms law, where  $V=I/R$ .

Where V is the applied voltage across the voice coil, I is the current flow thru the conductor (voice coil) and R is the dc resistance. As mentioned earlier, the force of interaction between the permanent magnet and the electro-magnet (the voice coil) is proportional to the current flow thru the coil. If the dc resistance of the voice coil is raised due to heating, then the current draw reduces and, as a consequence, the Lorentz force is reduced.

The change in Lorentz force as a function of dc resistance change/heating is referred to as Power Compression. As the electrical power applied to the voice coil increases the temperature of the voice coil increases. This increase in voice coil temperature increases the dc resistance and will reduce the current flow thru the voice coil. As the Lorentz force decreases due to reduced current flow the overall loudspeaker conversion efficiency is reduced.

It is desirable to minimize the heat rise associated with current flowing through the voice coil. Technical reviews of the heat produced by voice coils and subsequent performance alterations can be found in various professional journals. "Heat Dissipation and Power Compression in Loudspeaker", Douglas Button, J. Audio Eng. Soc., Vol. 40, No.1/2

1992, and “heat Transfer Mechanisms in Loudspeakers: Analysis, Measurement, and Design”, Clifford a. Henricksen, J.Audio Eng. Soc., Vol 35, No. 10, 1987 are typical examples of theoretical analysis and measurement of the thermal effects of loudspeaker voice coils.

A loudspeaker voice coil is comprised of a length of electrical conductor, typically copper or aluminum or some other alloy. The wire is wound into the shape of a coil whose dimensions are compatible with the dimensions of the permanent magnet gap as shown in figure 1. The coil is typically wound on a material known as a “bobbin” or “former”. This bobbin acts to support the voice coil and at its upper end serves as a location to bond the diaphragm, or cone. The bobbin material may be made from a polymer, heat resistant fabric, fiberglass prepreg, or aluminum. With the exception of an aluminum bobbin, all other materials also act as a thermal insulator and, as a result, the majority of the heat generated by the voice coil can only be effectively dissipated toward that portion of the voice coil away from bobbin. In the case of an aluminum bobbin the material itself can act as a good thermal path but the material is electrically conductive and the electrically conductive nature of the material allows “eddy currents” to be generated in the bobbin. These eddy currents are a secondary source of heat generation and they also produce magnetic fields that are of opposite polarity and will act to modulate and mitigate the primary electro-magnetic field. For this reason aluminum or other electrically conductive bobbins are rarely used in modern loudspeakers.

Figure 4 is an illustration of typical voice coil/bobbin configurations. The voice coil wire may be rectangular, round (both shown below), square, or any other geometry. Historically, voice coils have been wound on the outside surface of the cylindrical bobbin. Recently voice coils have been wound on both the outside and inside surface as shown below. These are referred to as “inside/outside” voice coils.

## Typical voice coil styles

Voice coil "bobbin" or "former"

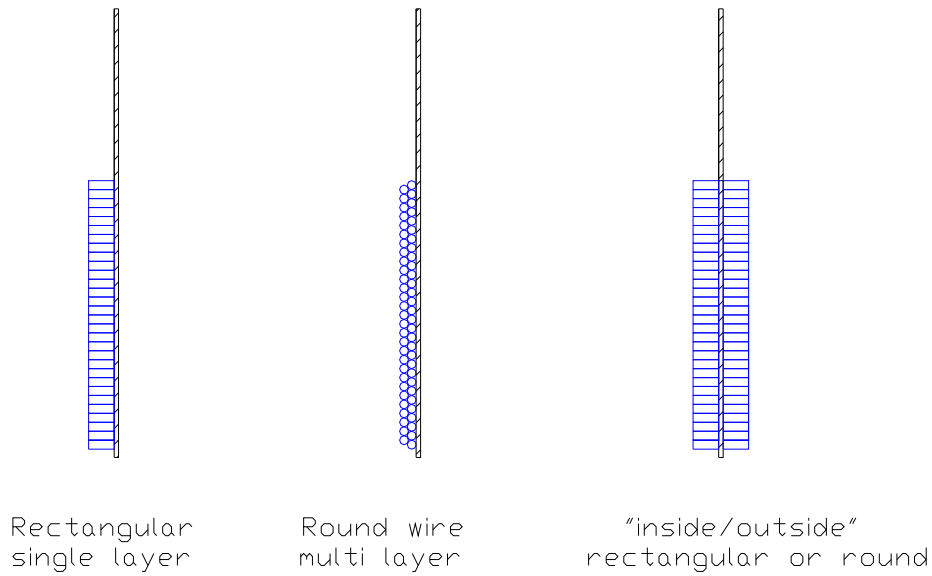

FIGURE 4

As can be seen in figure 4, the bobbin is represented by the black section to the right of the voice coil wire (shown in blue). The rectangular single layer coil offers excellent cooling except for the area where the bobbin is located. The round wire multi layer coil consists of 2 or more layers of round cross section wire. Because each layer of wire is surrounded by the wire insulator it will not cool as well as the single layer voice coil construction. Multi layer voice coils also have more turns than an equivalent single layer construction and, as a result, exhibit higher inductance which will affect the amplitude response at higher frequencies.

The "inside/outside" voice coil construction seeks to improve multi layer cooling by locating one layer to the outside of the bobbin and the second layer on the inside of the bobbin. This approach will offer improved cooling when compared to the multi layer "outside only" construction but still suffers from higher inductance as compared to the single layer design.

Loudspeaker voice coil heating/cooling is determined by several factors. One mechanism is conduction thru the magnetic gap to the surrounding low carbon steel return path.

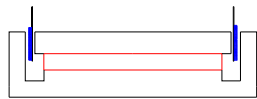
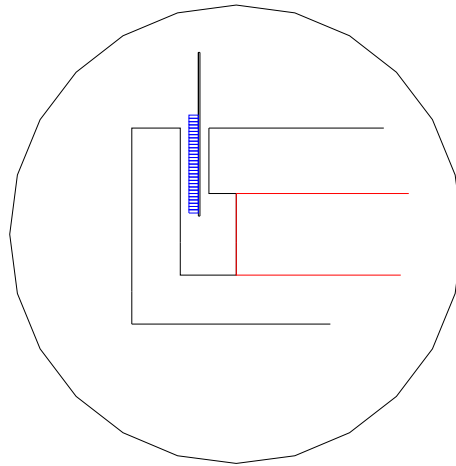

FIGURE 5

Figure 5 shows a pot core style design with the magnetic gap area enlarged for clarity. The voice coil and bobbin are “immersed” in the magnetic gap. The magnetic gap is defined by the inside diameter of the pot core and the outside diameter and height of the pole tip. The vertical height of the voice coil is made longer than the height of the magnetic gap in order to provide for a constant Lorentz force versus displacement. (i.e. for reasonable displacements a constant length of wire in the magnetic gap will produce a constant Lorentz force). The exact vertical height of the voice coil is a design parameter and will be a function of the desired linear displacement limits of the loudspeaker.

Figure 6 represents another enlargement of figure 5. The voice coil bobbin is shaded in black. The area to the inside, between the inside diameter of the bobbin and the outside diameter of the pole tip would represent a good path for conduction except that the bobbin is a thermal insulator. The voice coil in this drawing is a single layer rectangular wire coil and is shown in blue. The area shown in turquoise is a good heat conduction path. This is the area where the outside portion of the voice coil is in close proximity to the inside diameter of the pot core. The area shown in red, above the turquoise represents an area of poor conduction. The wire that extends above the pot core height is not in close

proximity to a portion of high thermal capacitance. This area will be hotter than that portion of the voice coil that is in close proximity to the pot core.

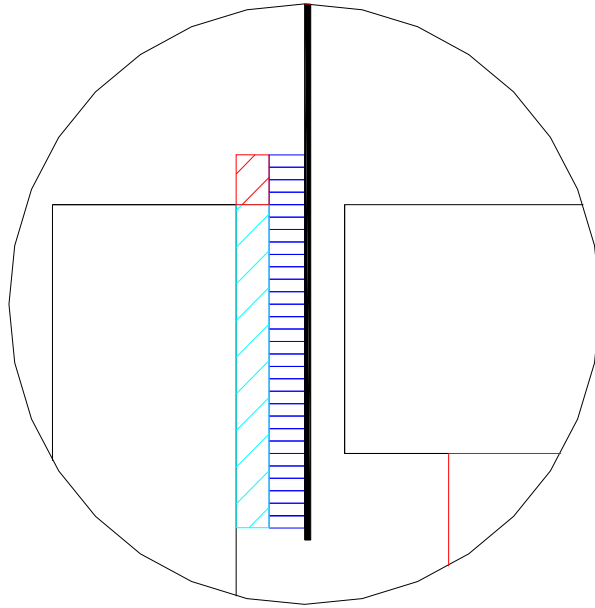

FIGURE 6

A common solution to the problem highlighted in figure 6 is shown below in figure 7.

It can be seen that a good solution is to extend the height of the pot core to extend beyond the vertical height of the voice coil. In this implementation the voice coil, regardless of vertical displacement, is always in close proximity to the inside diameter of the pot core. The magnetic gap is essentially unchanged and can actually be made more symmetric about the center horizontal center line of the pole tip.



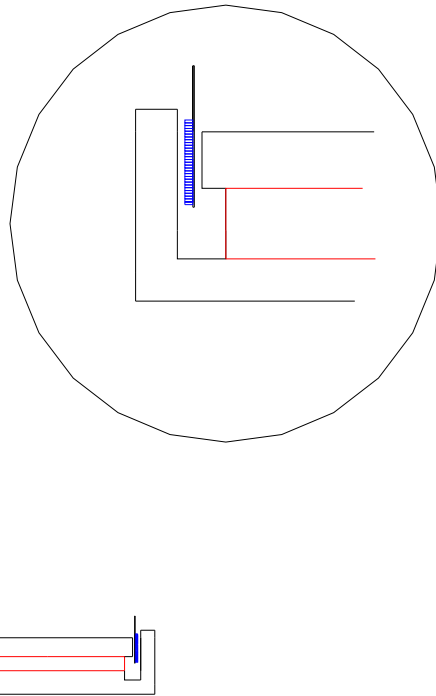

FIGURE 7

It can be seen in the above figure that the pot core vertical height now extends beyond the rest position of the voice coil and in fact can be made high enough to provide good conduction for large vertical displacements. For this design to be successful the voice coil suspension elements (commonly referred to as a spider) must be spaced high enough on the bobbin in order to prevent the under side of the suspension from physically hitting the top of the pot core. This technique is very effective in providing good thermal conduction.

Pot core designs are very efficient magnetically but suffer from a basic geometric flaw. If high Lorentz forces are required a large permanent magnetic field is required in the magnetic gap. A pot core design does not easily allow for the permanent magnet material to be of a large cross sectional area. The permanent magnet can be made larger in diameter but expensive and large additions of return steel are required to “neck down” the large magnet cross section to accommodate the outside diameter of the pole tip. (This technique was used frequently with ALNICO permanent magnets). Modern ultra high energy product permanent magnets, such as Neodymium Iron Boron must be relatively thin in their magnetic axis and this typically sets the geometry as shown in figure 1.

A good solution for increasing the permanent magnetic field is to use a “pancake” design as shown in figure 2. The “pancake” geometry allows the permanent magnet material

cross section to be as large as necessary or as large as manufacturing methods permit. Figure 8 is an enlarged view of a pancake design.

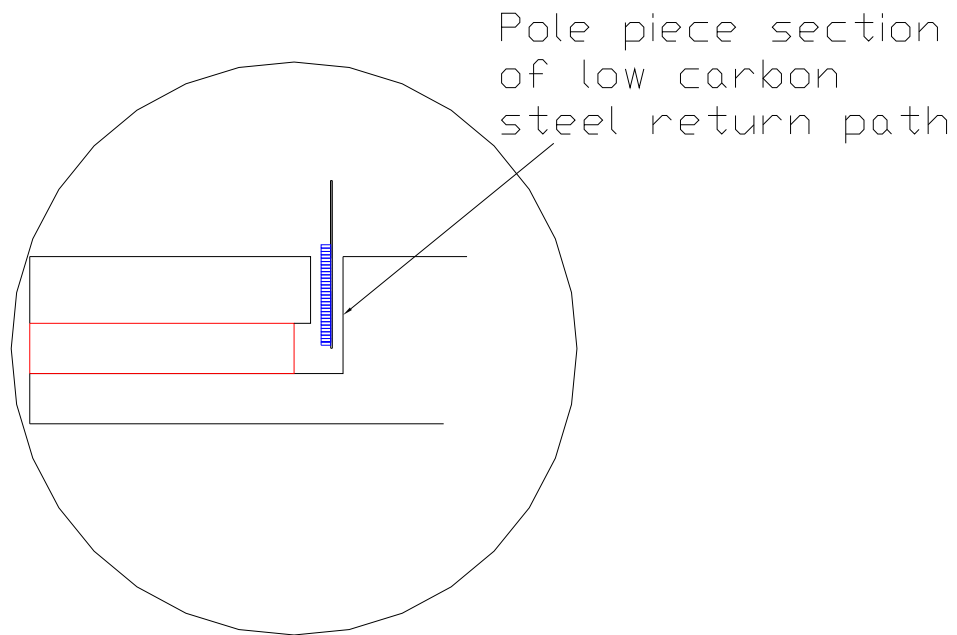

FIGURE 8

The enlarged view shown above illustrates the basic design concept. In this view the voice coil is shown vertically centered in the magnetic gap. The magnetic gap is defined by the outside diameter of the pole piece and the inside diameter and vertical height of the front plate. The vertical height of the voice coil extends both above and below the vertical height of the front plate and allows a relatively constant Lorentz force versus displacement as long as the displacement 0 to peak value is within the expression:

$$(\text{voice coil vertical height} - \text{front plate vertical height})/2$$

The sections of the voice coil that extend beyond the vertical height of the front plate are referred to as coil overhang. The portions of the coil that extend beyond, or overhang, the vertical height of the front plate will suffer from poor thermal conduction. Just like the

case represented in figure 6, for the pot core geometry, the coil sections that extend beyond the vertical height of the front plate will not be as cool as the portion in close physical proximity to the inside diameter of the front plate. The geometry of the pancake design is fundamentally different than that of the pot core design. Figure 7 shows the vertical extension of the pot core height and the associated additional thermal conduction. The physical height of the magnetic gap is maintained in figure 7 because the pole tip thickness defines the gap height.

Because the voice coil bobbin is a thermal insulator, the most effective conduction path still exists on the outside of the voice coil. To improve cooling in the pancake design the front plate thickness must be increased. Increasing this thickness, however, now modifies the magnetic gap and will produce an asymmetrical distribution of magnetic flux. This asymmetry will produce an asymmetrical Lorentz force that varies with voice coil displacement.

As shown in figure 4, another type of voice coil construction is the “inside/outside” style. This is shown in figure 9. It can be seen that in either design there are compromises in the thermal conduction of heat. The inside/outside design suffers in that the inside portion of the voice coil still presents cross sectional area both above and below the vertical height of the pole tip where thermal conduction is less than optimal. The pancake design has the same condition expect now the area of poor conduction is associated with the outside wind where the coil is “overhanging” both above and below the vertical height of the front plate.

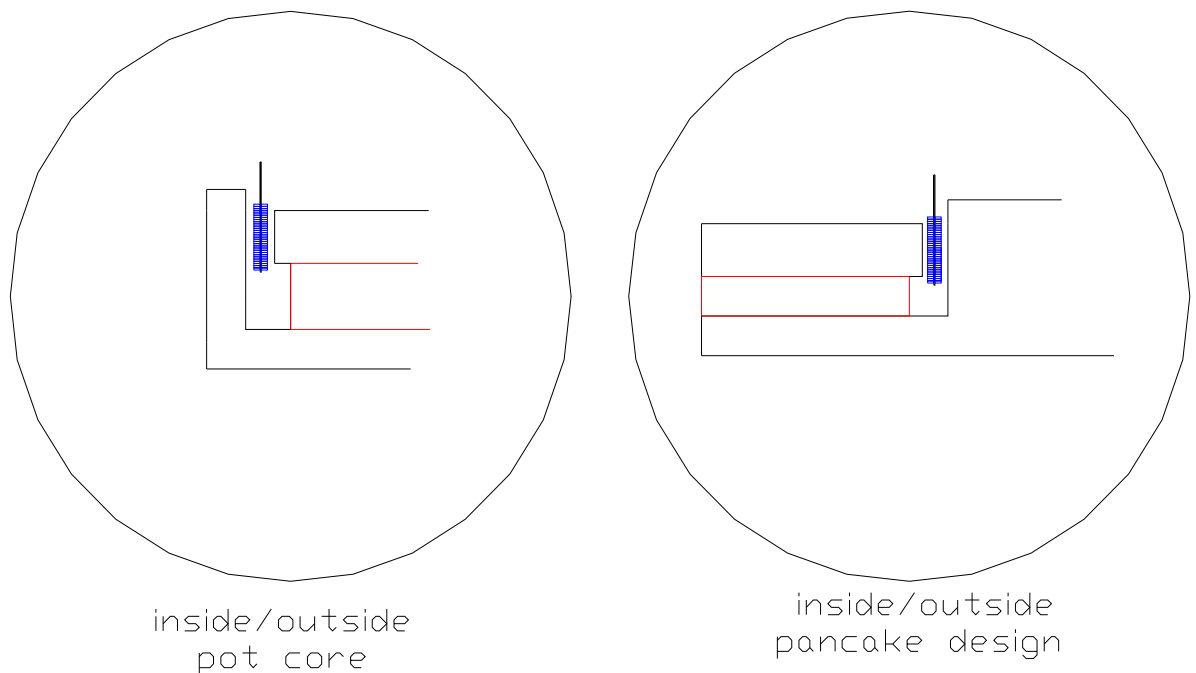

FIGURE 9

Prior art designs have attempted to deal with the thermal issues associated with the pancake design while still maintaining the magnetic gap symmetry but adding thermally conductive heat sinks above, below, and sometimes both above and below the front plate as shown in figure 10. The green shaded portions of figure 10 represent sections of thermally conductive material, typically aluminum both above and below the front plate. These are effective although the low electrical resistance associated with aluminum will allow large eddy currents to be induced into the “heat sinks” and become a secondary source of heat generation. In addition to the secondary generation of heat these additional parts represent additional expense and complexity. It is also not possible to accurately locate these parts and make them radially concentric with the front plate without adding a machining step to the assembly operation after all of the parts have been assembled but prior to the application of a protective coating (i.e. electroplating, e coating etc). This secondary machining operation is the only effective way to accurately insure that the inside diameter of the upper and lower heat sink pieces match the inside diameter of the front plate. It is typical to make the heat sink diameters of a larger inside diameter to avoid mechanical interference with the voice coil. Increasing this inside diameter reduces the proximity of the heat sink to the outside diameter of the voice coil and reduces thermal conduction.

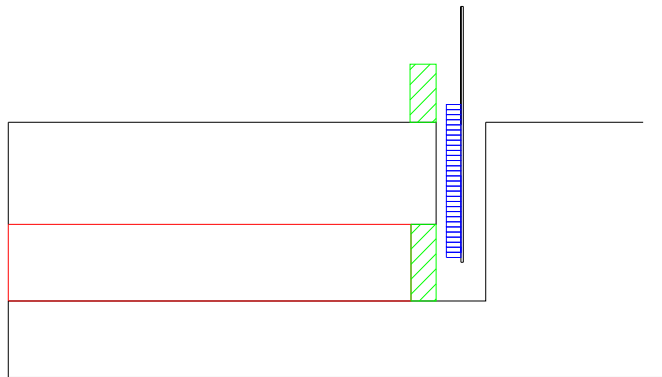

FIGURE 10

A new method is proposed that will wind the electrically conductive voice coil wire on the inside of the voice coil bobbin. Referred to as “inside only” technology, this novel approach offers the same level of thermal conduction that the pot core design offers but will allow the permanent magnet area and volume to be as required for high permanent magnetic field designs by utilizing the pancake style design. This geometry is illustrated in Figure 10. The voice coil is wound on the inside of the bobbin and the pole piece portions of the low carbon steel magnetic return path may be made as tall as required. This height, in a preferred embodiment will always be higher than the maximum physical displacement, or excursion, of the voice coil assembly. This will insure good thermal conduction regardless of physical displacement. This geometry does not alter the permanent magnet gap volume or symmetry. A disadvantage of the tall pot core design, as mentioned earlier, is that the suspension elements attached to the upper portion of the voice coil bobbin need to be physically spaced away from the top of the pot core so that the underside of the suspension elements do not touch the top of the pot core during maximum excursions. An advantage of the new inside only designs is that the suspension elements are not located on the inside diameter of the coil and, as a result, will not hit the top of the pole piece. A part of the diaphragm known as the “dust cap” is attached to the diaphragm above the pole piece but this part is easily spaced away from the top of the pole piece to allow for sufficient maximum required displacements.

In conventional designs, it is a common practice to make the gap between the inside diameter of the bobbin and the outside diameter of the pole tip (for pot core designs) or the pole piece (for pancake designs) smaller than that gap between the outside diameter of the voice coil and the inside diameter of the pot core (for pot core designs) or the front plate (for pancake designs). This is done to allow the voice coil assembly to expand physically as it heats. This conventional method requires more space on the outside of the coil so that as the voice coil assembly increases in diameter it will not come into contact with the inside diameter of the pot core or front plate. If the voice coil wire touches the pot core or front plate it will produce an audible rub, or distortion, and frequently will produce a catastrophic failure of the loudspeaker by producing an electrical short circuit or open circuit.

The conventional design geometry allows the voice coil to expand toward the pot core or front plate.

The unique geometry of Inside Only technology allows the voice coil to expand away from the pole piece or pole tip rather than toward it. This geometry will result in a rubbing of the voice coil bobbin on the inside diameter of the front plate. This arrangement will act to prevent catastrophic electrical failures from occurring.

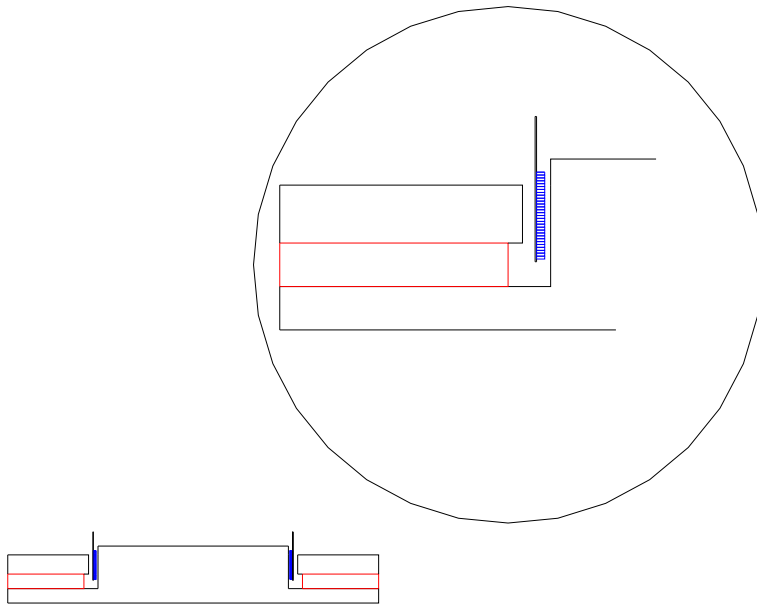

FIGURE 10  
INSIDE ONLY TECHNOLOGY

What is described is a unique and cost effective method to provide an increased thermal conduction to a loudspeaker voice coil. Prior art methods are described and each method is associated with its individual short comings. Inside Only technology offers high thermal conductivity for the entire vertical voice coil height. It can easily provide for cooling regardless of voice coil physical displacement. It can equal the cooling provided by pot core designs but has the advantage of being able to accommodate larger permanent magnet cross sections, and hence physical volumes to provide for higher permanent magnetic fields in the magnetic gap. Inside only designs do not require the spacing of the loudspeaker suspension elements to be spaced farther away from the top of the voice coil to accommodate the increased height of the pot core as is the case with pot core designs. Inside Only technology offers superior protection from catastrophic rubs and electrical short and open circuit failures.

Inside Only voice coil designs provide for excellent thermal conduction while also allowing the use of pancake style permanent magnet designs.



**ONE SYSTEMS®**

**One Systems USA, Inc.** \* 6204 Gardendale Dr. \* Nashville, TN 37215

**One Systems Group Co. Ltd.** \* European Division \* Mittelsmoorer Strasse 12 \* 28879 Grassberg German

**One Systems Global Co., Ltd.** \* 87/114 Modern Town 15<sup>th</sup> Floor \* Sukhumvit 63, Ekkamai Soi 3, Klongtoey, Bangkok, 1010 Thailand