



Features

- 1.79" Voice Coil
- Extended Frequency Response
- Excellent Full Range Performance
- Precision Wound High Reliability Coil Design
- Computer Optimized Ferrite Magnet
- Heavy Gauge Steel Chassis Design

Applications

The P Audio TC-150N is a high output wide range transducer. The TC-150N is an upgraded design that features many of P Audio's new technologies and performance upgrades. The 12 inch (305mm) diameter piston will produce high sound pressure levels at low frequencies but also exhibits an extended high frequency response that makes the TC-150N a full range device. The operating bandwidth of the TC-100 is 80Hz-14000Hz. The transducer uses high energy ferrite magnetics to achieve a very high acoustic output to weight ratio.

The TC-150N employs a medium format 1.79 inch (45.5mm) diameter voice coil that provides an AES rated 150 watts of continuous power handling and a full 450 watts of peak rated power handling when sufficient amplifier headroom is available. The TC-150N utilizes P Audio's under damper venting technology to improve transducer air flow and reduce turbulence under the damper and around the voice coil.

The voice coil design is a bobbin wound geometry with P Audio's precision round wire technology that maximizes system conversion efficiency and cooling.

The Suspension has been designed specifically for high linear displacement and extended low frequency response.

The transducer chassis is a heavy gauge stamped steel design that insures a very high degree of structural integrity.

Specifications

General Specifications

Nominal diameter.....	305 mm/12 in
Power rating.....	150 W(AES)
Nominal impedance.....	8Ω
Sensitivity.....	99 dB
Frequency range.....	80-14000 Hz
Chassis type.....	Heavy Duty Steel
Magnet type.....	Ferrite
Magnet weight.....	49.7 oz
Voice coil diameter.....	45.5 mm/1.8 in
Coil material.....	Copper Wite
Cone material.....	Paper
Surround material.....	Cloth
X-max.....	1× mm
Gap depth.....	.8 mm/0.31 in

Thiele Small Parameters

FS.....	51 Hz
Re.....	5.89Ω
Qms.....	14.55
Qes.....	0.58
Qts.....	0.56
Mms.....	39.18 g
Mmd.....	31.73 g
Vas.....	104.64 lt
Sd.....	551.5 cm ²
Bl.....	11.30 Tm
Cms.....	2.5e-04 m/N
Rms.....	0.87 Ns/m
Le (at 1kHz).....	0.46 mH

Packing Dimensions

WxDxH (mm)..... 335 x 335 x 175

Weight

Net Weight..... 4.26 kg
Shipping Weight..... 4.82 kg

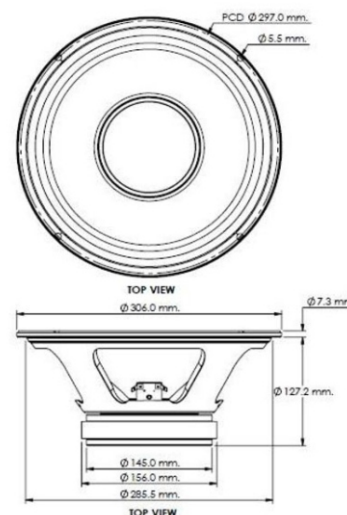

Frequency Response & Impedance Curve

