



# GM SERIES

# GM8-65N

Low Frequency Neodymium Woofer



## Features

- 2.5" Voice Coil
- 1000 Watts Peak Power Handling
- 96 dB Sensitivity
- FEM Designed Neodymium Magnetics
- Precision Rectangular Ribbon Coil Design
- Triple Aluminium Demodulation Rings

## Applications

The P. Audio 'Golden Master' GM8-65N is the intersection of advanced design and state of the art manufacturing. The GM8-65N is an 8 inch (203mm) mid/low transducer for high performance professional audio. The 2.5 inch (63.7mm) voice coil is designed for superior reliability and excursion, featuring low weight, high temperature rectangular aluminium wire and extended winding length. The low-weight neodymium magnetics maximize the coil's strengths by providing strong magnetic flux across its whole range of movement. This keeps coil motion faithful to the audio signal without distorting. Aluminium 'demodulation' rings negate inductance effects in the motor, further improving the fidelity of coil movement.

The neodymium magnet structure cooperates with a carefully optimized venting system on the bottom of the sleek Golden Master chassis to control airflow around the voice coil. This cools the durable design to further levels of reliability without losing sensitivity – the GM8-65N is rated at 1000 W peak power handling/ 250 W AES continuous power handling with nominal sensitivity of 96 dB.

Linear and symmetrical stiffness behavior of the suspension compliments linear coil motion. The GM8-65N's spider features roll geometry designed to provide symmetrical displacement, even at high power levels. The cone features a proprietary double-roll cloth surround. The perfect match of material and geometry mean ultra-low distortion of cone movement and ultra-low distortion of sound. Custom cone pulp provides light waterproofing, while low moving mass has been optimized for high performance 8" two-way designs.

The ideal application for the GM8-65N is in very high performance sound reinforcement and large format public address systems. It is ideal for use in a well-tuned vented enclosure in a range of configurations – general purpose sound reinforcement systems, mid/mid-bass applications and floor monitors. The high efficiency rating allows the GM8-65N to be used as the low frequency section of small/medium format line array designs where a subwoofer is also used. Performance is optimized when using a high pass 4th order Butterworth filter tuned near the enclosure vent frequency. The GM8-65N offers an 85-3500Hz useable bandwidth, though the actual crossover frequency will be determined by the driver and horn combination in the user's system.

## Frequency response and Impedance curve

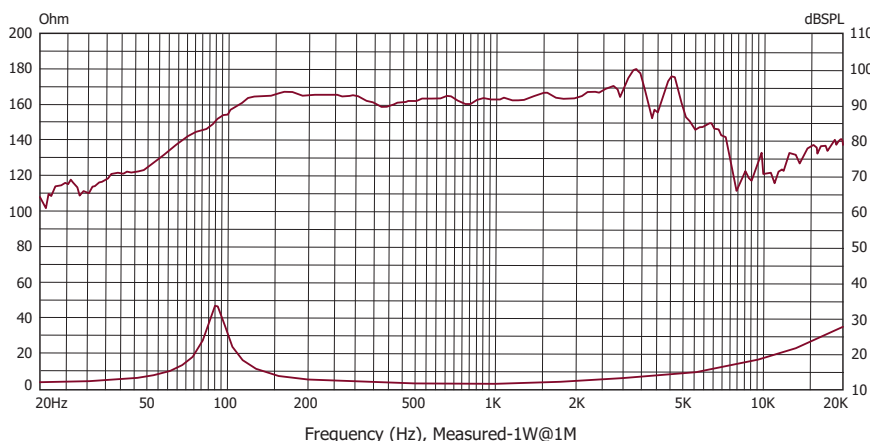

## General Specification

Nominal diameter	203 mm / 8 in
Peak Power	1000 W
AES Power	250 W
Nominal impedance	8 Ohm
Sensitivity (1W/1m)	96 dB
Frequency range	85 - 3500 Hz
Chassis type	Cast Aluminium
Magnet type	Neodymium
Magnet weight	0.21 kg / 7.3 oz
Voice coil diameter	63.7 mm / 2.5 in
Coil material	Edge Wound Aluminium Wire
Former material	Kapton
Cone material	Paper
Surround material	Cloth
Suspension	Single Spider
Xmax	-2 mm / -0.08 in
Gap depth	16 mm / 0.63 in
Voice coil winding width	12 mm / 0.47 in
Unit weight	2.4 kg / 5.3 lb
Shipping weight	3.1 kg / 6.8 lb
Packaging dimension WxDxH	210x210x120 mm 8.3x8.3x4.7 in

## Thiele Small Parameters

Fs	89 Hz
Re	5.4 Ohm
Qms	5.79
Qes	0.47
Qts	0.43
Bl	12.19 Tm
Mms	23.09 g / 0.82 oz
Mmd	21.12 g / 0.75 oz
Vas	9.99 lt / 0.35 cu.ft <sup>3</sup>
Sd	227 cm <sup>2</sup>
Le	0.42 mH
Cms	1.4e - 04 m/N
Rms	2.3 Ns/m

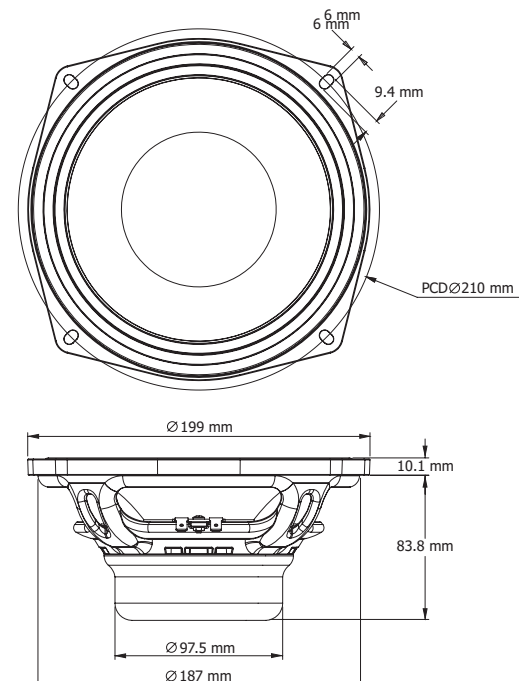

P.AUDIO SYSTEM CO.,LTD.