

# Dynatech

## OPERATING MANUAL

MODEL: MS-14

### Content List

- 1.Receiver.....X1
- 2.Handheld Mic  
(Bodypack).....X2
- 3.Power Adapter.....X1
- 4.Audio Cable.....X1
- 5.Manual.....X1

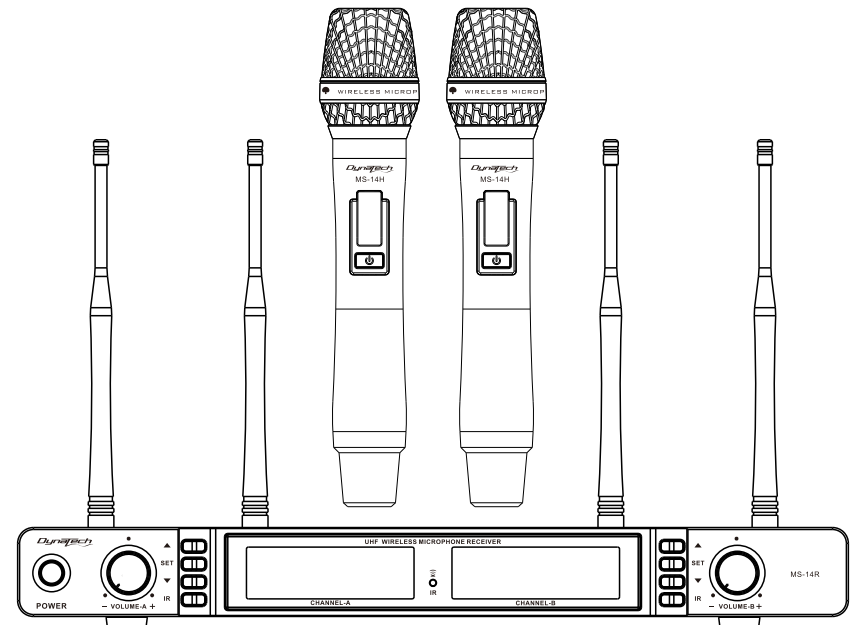

Thank you for your choosing on our products. Please do read this manual carefully before use.

## CONTENTS

Contents..... 1  
 Brief Introduction..... 2  
 Main Features.....2  
 Parts (Receiver).....3  
 Receiver LCD Display..... 4  
 Handheld Mic Operation.....6  
 Bodypack Operation..... 7  
 Receiver Operation.....8  
 Technical Specification..... 9  
 Warning.....10

## REMINDER

Please do read this manual carefully before using. Wireless microphones can scatter radio energy, please do follow the instruction to install and operate in case causing harmful influence. Do abide local radio regulations when using wireless microphones. We can offer you frequency of 550-960MHz products, and please choose specific range according with local radio regulations; otherwise, you will take full responsibility of all consequences.



- Do place receiver in open space, so that it can receive signal better;
- Do not throw the device;
- Do not place device under rain or drop it into water;
- Keep device away from sunshine or electromagnetic field;
- Do insert batteries in right way, and remove them if device is idle for long time;
- Cut off power supply before battery replacement;
- Pull out power adaptor from power supply if receiver is idle for long time;
- Do not take apart device without permission, in case users are injured;
- Device doesn't contain any part for self refitting, otherwise, warranty will be void;
- Use soft cloth to clean device, if there's any stubborn stain, clean it with neutral detergent but not volatile gasoline or thinner;
- Keep at least 30CM space around device for better ventilating;
- Do not cover ventilation hole with paper, tablecloth or curtain;
- Do not put fire on device like burning candle;
- Keep device away from water drops, or any container with liquid like vase;
- Do not use new and old batteries at the same time, besides, replace them with same kind batteries; Discarding batteries to specific recycling bin;
- Working temperature: 5°C- 60°C;

Please try below methods to solve interfered problem when using wireless microphones

- Adjust place or direction of the antenna;
- Keep away from radio or TV;
- Do not plug in same electrical socket outlet with radio or TV;
- The best angle is 45° for mouth and microphone when speech, in order to reduce affected by airflow from mouth;
- Using 1 microphone when 1 sound input, otherwise sound will be mixed;
- Keep distance of mouth and microphone less than 15CM because of cardioid pickup, otherwise bass is not good;

**COPYRIGHT:**  
 All Right Reserved.

## VIII. TECHNICAL SPECIFICATION

- RECEIVER

Carrier Frequency: UHF640-690MHz

Bandwidth: 50MHz

Dynamic Range: 96dB

Distortion: <0.1%

Frequency Response: 30-20KHz/±2dB

Signal/Noise Ratio: 96dB

Sensitivity: -95dBm

Power Supply: DC12V 1A

Audio Output: 1×6.3mm, 2×XLR balance output

- HANDHELD & BODYPACK MICROPHONE

Carrier Frequency: UHF640-690MHz

Bandwidth: 50MHz

Frequency Switch: IR SYNC

Output Power: 10mW-30mW (depends on frequency band)

Harmonic Radiation: <-50 dBc

Battery: 2×1.5V AA battery

Battery Life: >5h

## I. BRIEF INTRODUCTION

Wireless microphone system is very easy to install and convenient to use, the first choice for singers. This model

Adopts intelligent cryptographic hardware, to achieve unique sound and RF performance.

Frequencies group, colorful LED display and humanized menu make it easy for single or multi-sets installation.

## II. MAIN FEATURES

- Optional UHF band 640-690MHz
- Unique digital 16 bit ID pilot technology, no crosstalk disturbance even in same frequency.
- LCD display on receiver shows frequency and battery condition.
- Adopt single chip design, with true diversity function to avoid dead point.
- Auto frequency scanning and user set frequency function.
- Suitable for stages, ballrooms, conference rooms, speech and home entertainment.
- Ideal distance: longer than 80M in open space.

### III.PARTS (RECEIVER)

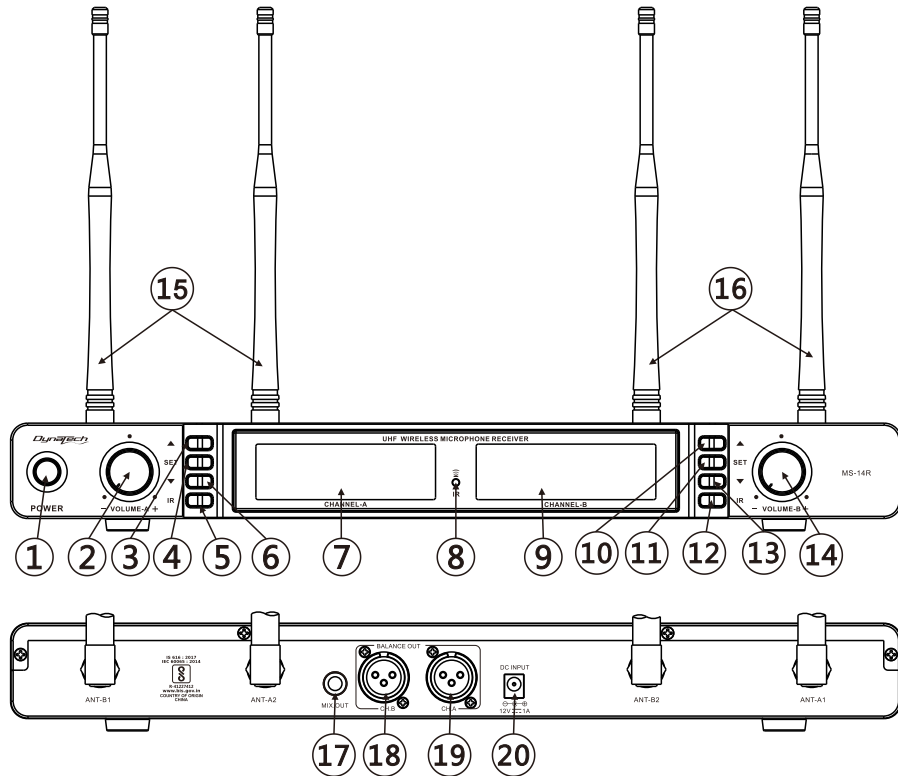

- |                           |                            |
|---------------------------|----------------------------|
| 1. POWER                  | 11. FUNCTION / UNLOCK-B CH |
| 2. VOLUME-A CH            | 12. IR-B CH                |
| 3. UP-A CH                | 13. DOWN-B CH              |
| 4. FUNCTION / UNLOCK-A CH | 14. VOLUME-B CH            |
| 5. IR-A CH                | 15. ANTENNA CH             |
| 6. DOWN-A CH              | 16. ANTENNA CH             |
| 7. LCD DISPLAY-A CH       | 17. MIX. OUT               |
| 8. IR INDICATOR           | 18. BALANCE OUT-B CH       |
| 9. LCD DISPLAY-B CH       | 19. BALANCE OUT-A CH       |
| 10. UP-B CH               | 20. DC INPUT               |

### VII. RECEIVER OPERATION

- **Power Connection:**  
Connect the attached adaptor to DC input port (20).
- **Audio Output Connection:**  
Mix Output: connect one end of the attached audio cable into OUT. MIX port (17), meanwhile connect the other end to MIX IN or AUX IN port of mixer or speaker.

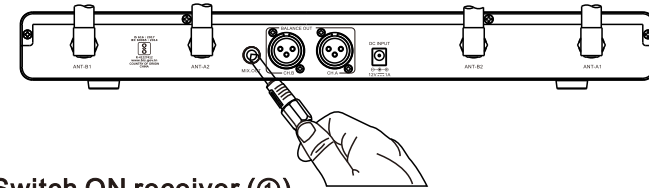

- Switch ON receiver (1).

### SNYC IR Operation

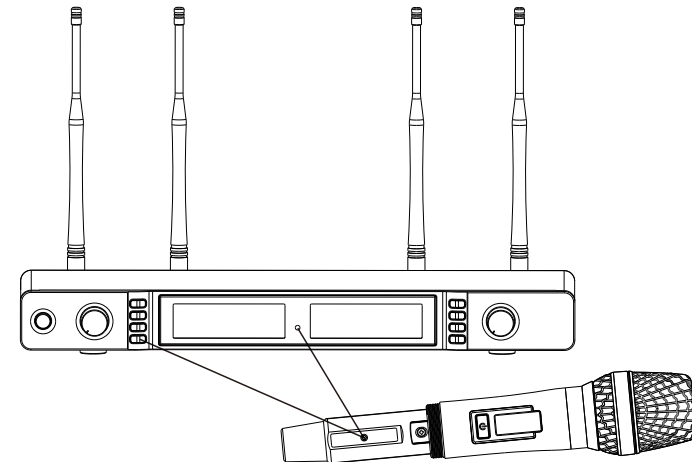

SNYC IR operation shows as above picture. Boot up receiver, firstly long press UNLOCK button to unlock system, and then choose non-interference frequency, and then long press IR button for 3 seconds till the IR indicator flashing and transmit IR signal, meanwhile, boot up microphone and keep its IR window close to receiver's. Same frequency will show on microphone and receiver at the same time when IR SNYC successfully, and RF signal will show on LDC on receiver.

▶Handheld Microphone Holding Ways

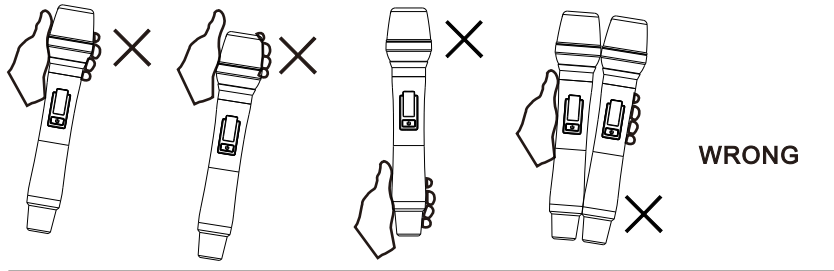

WRONG

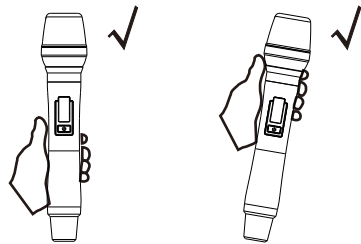

CORRECT

- ▶Keep distance of mouth and mic head less than 15CM.
- ▶Avoid using mic head to point to speakers.

VI. BODYPACK OPERATION

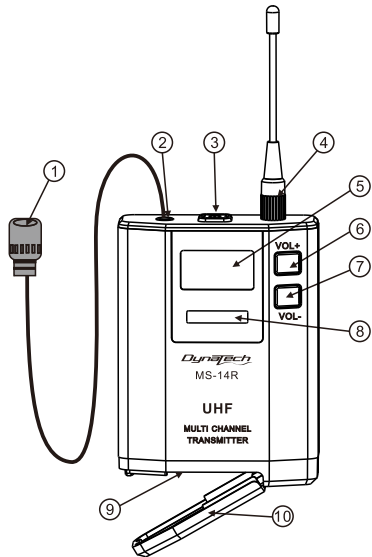

- 1.Microphone: pick up sound.
- 2.Input Socket.
- 3.ON/OFF: power switch.
- 4.Antenna.
- 5.OLED: indicates bodypack working status.
- 6/7.-VOL+: volume control.
- 8.IR: SYNC IR signal with receiver IR window.
- 9.Battery Sink: insert 2×1.5VAA batteries, be awarded to insert them in correct polarity.
- 10.Battery Cover.

IV. RECEIVER LCD DISPLAY

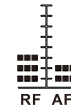
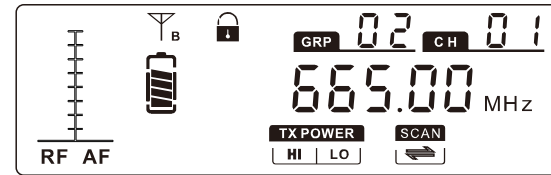

RF: Indicate signal intensity, the longer length of the color, the stronger signal.  
 AF: Indicate audio level, the longer length of the color, the stronger signal.

Diversity signal symbol

Receiver system is in LOCK condition

Power of working handheld microphone

Receiver working frequency is 665.00MHz; Group02; Channel 01

Transmitted power setting menu

Frequency scanning menu

### Receiver LCD Functions Setting

#### Frequency Setting

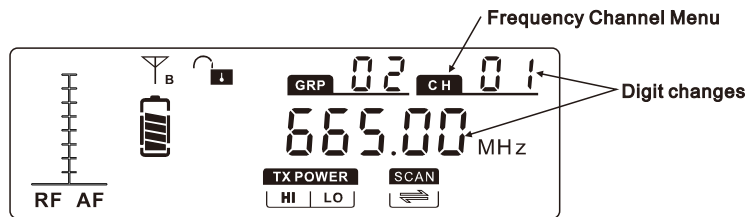
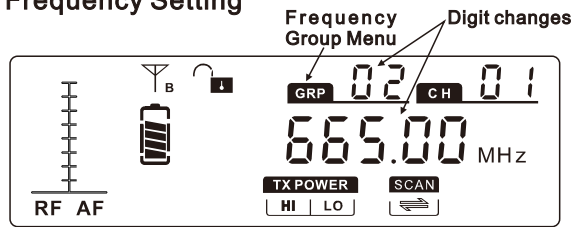

#### ● Transmitted Power Setting

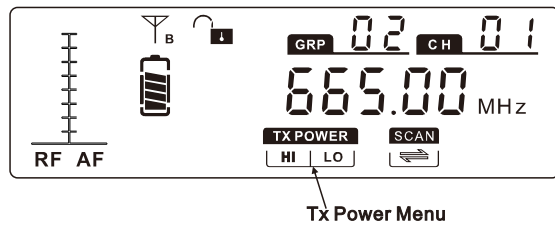

NOTE: Above function can work properly only if re-SYNC after setting.

#### ● Frequency Scan Setting

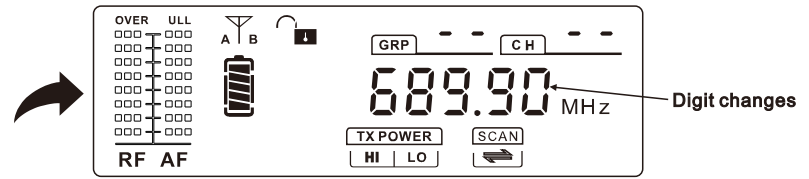
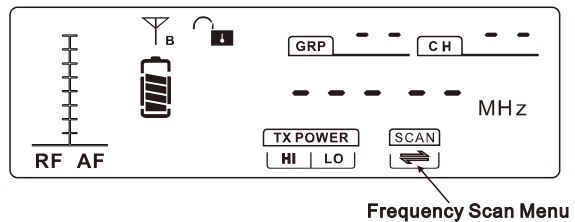

### V. HANDHELD MIC OPERATION

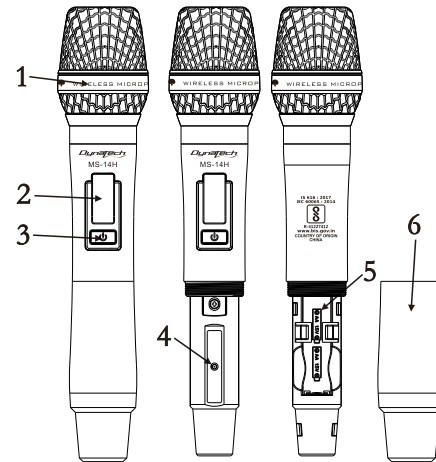

1. Microphone Capsule: pick up sound.
2. LCD: indicates microphone working status.
3. ON/OFF Switch: control handheld microphone to be power on, off or mute.
4. IR window: SYNC IR signal with receiver IR window.
5. Battery Sink: insert 2×1.5VAA batteries, be awarded to insert them in correct polarity.
6. Mic Cap: unscrew it when change batteries.